

INSTRUCTIONS
for
STABILINE[®]
Automatic Voltage Regulator

WHR5206

Single Phase
240 X 208 Volt

Superior Electric reserves the right to make engineering changes on all its products. Such refinements may affect information given in the instructions. Therefore, **USE ONLY THE INSTRUCTIONS THAT ARE PACKED WITH THE PRODUCT.**

WARNING: High voltages are present inside this unit during operation. Do not operate this unit unless all covers are in place. Installation and servicing should only be done by qualified personnel.



TABLE OF CONTENTS

SECTION	PAGE	SECTION	PAGE
1.0 INSPECTION	2	6.0 MAINTENANCE	5
1.1 UNPACKING	2	7.0 TROUBLESHOOTING	5
2.0 DESCRIPTION	2	8.0 RATING	7
2.1 GENERAL	2	9.1 POWER RATINGS	7
2.3 THEORY OF OPERATION	2	9.3 GENERAL SPECIFICATIONS	7
3.0 INSTALLATION	2	9.0 REPLACEMENT PARTS	8
3.1 MECHANICAL INSTALLATION	2	9.1 ORDERING	8
3.2 ELECTRICAL INSTALLATION	2	9.2 CONTROL MODULE ASSEMBLY	8
4.0 START UP	3	9.3 POWER COMPONENTS	9
5.0 OPERATION	3	9.4 REPLACEMENT BRUSH ASSEMBLY ..	9
5.1 CONTROL MODULE ASSEMBLY	3	10.0 SCHEMATIC	10
5.2 SETTING OUTPUT VOLTAGE AND SENSITIVITY POTENTIOMETERS	3		
5.3 REMOTE SENSING	4		

1.0. INSPECTION

1.1. UNPACKING

When unpacking the unit, examine it carefully for any shipping damage. The "Damage and Shortage" instructions packed with the unit outlines the procedure to follow if any parts are missing or damaged.

2.0. DESCRIPTION

2.1. GENERAL

WHR5206 STABILINE® Automatic Voltage Regulators are single phase, 240 X 208 volt, fast acting electromechanical regulators. These units have an analog electronic control section and a power section consisting of a motor driven POWERSTAT® Variable Transformer and a buck-boost transformer.

Advantages of all WHR Series voltage regulators include high efficiency (99% typical), high overload capacity and low impedance. These voltage regulators are insensitive to the magnitude and power factor of the load, and have little to no effect on system power factor. This means these regulators can be used with any type load.

2.2. THEORY OF OPERATION

These units regulate AC voltage by automatically adjusting POWERSTAT® Variable Transformers to maintain constant output voltage.

The solid-state control unit detects output voltage, and continually compares it with output and accuracy settings selected by the user. If the output is out of specifications, the control unit drives the POWERSTAT variable transformer by means of a synchronous motor, to the required new position.

3.0. INSTALLATION

3.1. MECHANICAL INSTALLATION

The regulators are designed for bench or rack mounting. When mounting the unit, allow a minimum clearance of 4 inches (100 mm) behind and above the unit for proper ventilation.

Note: When rack mounting a WHR Series regulator, it is recommended that support be provided for the rear of the unit.

3.2. ELECTRICAL INSTALLATION

All WHR regulators are designed to be hard-wired to the input power and the load using copper wire. When these units increase low input voltage to give nominal output voltage, the input current is substantially higher than the output current. Maximum rated input and output currents are given in the enclosed rating chart. Select a wire size that is adequate to carry the maximum rated current as specified by local and national code requirements.

The terminals for input and output connections are located on the rear of the regulator. A ground stud is provided on the chassis of the unit. The terminals for making the input and output connections are on a terminal panel. The input terminals are labeled L1 and L2-NEUT. The load connection terminals are labeled T1 and T2-NEUT.

The ground terminal must be connected to a suitable earth ground to reduce the chance of electrical shock.

4.0. START UP

Set the Output Voltage Range toggle switch on the control module to either the 240 or the 208 volt position to match your application. Use the 240 volt position for 220 and 230 volt systems. The Output Voltage Adjustment and the Sensitivity potentiometers are set at the factory for nominal output voltage and approximately 1% accuracy, and should not be readjusted until the voltage regulator is initially energized.

After all input and output connections are completed and checked, ensure the chassis panel(s) are in position and tightly fastened.

Energize the regulator power source. The voltmeter should indicate the output voltage (approx. 240 or 208 volts), and the POWER pilot lamps and the CONTROL pilot lamps should be lit. This indicates the voltage regulator is operating properly.

5.0. OPERATION

5.1. CONTROL MODULE ASSEMBLY

5.1.1. General

The control modules contain the circuitry that sense the output voltage and determine if correction is needed. On rack models the control module is the front panel and the components mounted to it. When correction is required this circuit sends a raise or lower signal to the motor driven variable transformers. To eliminate accidental tampering of the control module settings a cap is provided to cover the control potentiometers.

5.1.2. Power Pilot Lamps (A1-LP1)

The POWER lamp on the control assembly lights when power is present for the motor. This indicates the voltage regulator is energized.

5.1.3. Control Pilot Lamps (A1-LP2)

The CONTROL lamp lights when the control assembly sense voltage is energized. The control sense voltage must be energized for automatic correction of voltage changes to occur.

5.1.4. Analog Voltmeters (A1-M1)

The front panel meter shows the output voltage. This is the voltage being sensed by the control module. If remote sensing is used the meter will read the remote voltage being produced on the remote sense terminals.

5.1.5. Output Voltage Range Toggle Switches (A1-S1)

With these switches in the OFF position, the control sense voltage is disconnected and the control pilot lamp is not illuminated. In this position automatic correction for voltage changes will not take place and any change in input voltage will be reflected in output voltage. The switch should be placed in either the 240 or 208 position

to energize the control assembly sense voltage and allow automatic correction of voltage changes.

5.1.6. Output Voltage Potentiometers

This potentiometer sets the output voltage. The adjustment range is approximately $\pm 10\%$ of selected nominal output voltage.

5.1.7. Sensitivity Potentiometers

This potentiometer adjusts the voltage regulator's output accuracy and therefore set how much the output voltage will change before the unit will correct.

5.1.8. Fuses (A1-F1 to A1-F4)

The four fuses located on the control module protect the motor and sense power lines. If the POWER or CONTROL lights are not lit, and all control settings are proper, check for a blown fuse.

5.2. SETTING OUTPUT VOLTAGE AND SENSITIVITY POTENTIOMETERS

5.2.1. Energize Regulator

Energize the regulator power source. The pilot lamps should light, indicating that the voltage regulator is energized and that the control unit is on. If necessary, move the OUTPUT VOLTAGE RANGE switch to the desired nominal output voltage position. The voltmeters will indicate the output voltages.

5.2.2. Set Output

Adjust the output voltage if necessary by turning the OUTPUT VOLTAGE potentiometer. Clockwise will increase the voltage and counterclockwise will decrease the output voltage. The voltmeter will indicate the changes.

5.2.3. Set Sensitivity

The sensitivity must be adjusted if the voltage regulator hunts (the motor driven variable transformer sections of the regulator continually cycles back and forth) or if the regulator allows too great a change from the set voltage before correction occurs.

Turning the SENSITIVITY control clockwise increases the sensitivity to maximum ($\pm 0.5\%$ output voltage accuracy). For maximum sensitivity, turn the SENSITIVITY control clockwise to the point where the POWERSTAT begins to hunt. Turn the control counterclockwise (CCW) until the hunting stops. Turn the control an additional 1/8 turn CCW.

5.3. REMOTE SENSING

Normally, the voltage WHR series regulators sense and regulate the voltage at the regulator's output terminals. In some cases better control can be obtained by regulating the voltage at another point, such as at the end of long lines between the regulator and the load. This is known as remote sensing.

If remote sensing is desired, remove the jumper wire connecting terminal 1 to terminal 3 and the jumper wire connecting terminal 2 to terminal 4 on the remote sensing terminal strip at the rear of the unit. These jumpers are wht/red and wht/grn respectively. This will disconnect the control module sense terminals from the output terminals of the regulator. Connect remote sensing wires corresponding to the output load voltage to terminals 3 and 4 on the remote sensing terminal strip.

The sense voltage must be controlled by the voltage regulator. If the control is not sensing a voltage controlled by the regulator's output, the POWERSTAT connected to that control unit will drive to the end of its travel when it attempts to correct the voltage it is not controlling. This will result in incorrect output voltages.

6.0. MAINTENANCE

To ensure maximum life of the equipment, the following should be part of an **annual** maintenance program.

Warning

De-energize unit before performing maintenance. Voltages are present inside this unit which can cause injury. Therefore, only personnel qualified to service electrical equipment should perform maintenance on this unit.

6.1. Vacuum the voltage regulator inside and out to remove accumulated dirt, which could lead to overheating or insulation failure.

6.2. Tighten all electrical connections, particularly all power wiring to, and in, the unit.

6.3. Inspect all variable transformer brushes and commutators for signs of wear or pitting. Replace as required. See diagram below.

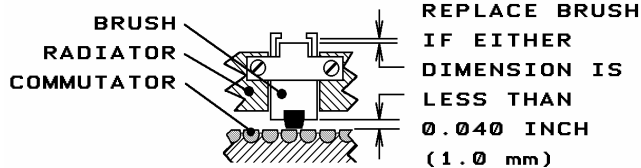

Do not attempt to clean a commutator with an abrasive such as sandpaper or a file. This will ruin the soft precious metal plating on the commutator and will shorten the life of the unit. It is normal for commutators to become black due to carbon brush tracking. If a commutator is to be cleaned, use denatured alcohol and a soft cloth.

6.4. Inspect the variable transformer drive belts, sprockets, gears, cams, etc. for signs of slippage or wear and adjust as required.

6.5. Check the variable transformer radiator(s) (the die cast part that holds the brush assembly) for signs of slippage, and see if all brushes driven by the same motor are aligned with each other. The alignment of the radiator and brushes depends on the setscrews that hold the variable transformer center tube(s) to the shaft and the setscrews that hold the radiator to the center tube. Adjust and tighten as needed.

6.6. Lubrication of the WHR Series voltage regulator is not required since it has been lubricated at the factory for its lifetime.

7.0. TROUBLESHOOTING

WHR Series voltage regulators will provide long, reliable service with little attention. Unless the unit is overloaded, there is little likelihood of component failure.

Warning

Voltages are present inside this unit which can cause injury. Therefore, only personnel qualified to service electrical equipment should perform trouble-shooting procedures on this unit.

If the regulator fails to operate correctly, the following checks will help locate and correct the problem. Refer to the schematic, rating chart and replacement parts list for further information.

7.1. Check the load connected to the voltage regulator to be sure the unit's output current rating is not being exceeded.

7.2. See if the POWER pilot lamps are on. If a lamp is not on, there is no power to the voltage regulator, or fuses F1 & F2 (POWER LIGHT MOTOR) on that control module are blown, or the lamp has burned out. Check the POWER LIGHT MOTOR fuses (F1 and F2). Check the power input to the unit to be sure the voltage is within the range specified for the selected output voltage.

7.3. Check the output voltmeters. If a meter shows zero output voltage, check the input line, control module fuses F3 and F4 (CONTROL fuses), remote sense wiring if applicable, and input connections. If so equipped, check position of input circuit breaker and manual bypass switch.

7.4. Check the CONTROL pilot lamps. If one is not lit, check the VOLTAGE RANGE switch to be sure it is on and check for blown CONTROL fuses (F3 and F4). If applicable, check the remote sense wiring.

7.5. If the motor hunts (cycles continuously), readjust the SENSITIVITY control.

7.6. If a motor drives a POWERSTAT variable transformer to one end of its travel, and the voltage decreases when it should increase or increases when it should decrease, check to see if the input and output power connections to the voltage regulator are reversed. If applicable, check the remote sense wiring.

If the unit has been reworked or repaired, check to see if the leads driving the motor have been reversed. A1-TB1-2 and A1-TB1-3 provide the motor power to lower and raise the motor with A1-TB1-1 being the common for both AC voltages.

7.7. If the motor continues to hum or buzz after the OUTPUT VOLTAGE RANGE switch is turned off, the solid-state switch controlling the motor may be

defective. De-energize the input line to the voltage regulator, and replace the control board.

7.8. If the motor has driven to one end or does not drive at all, check to ensure the motor drive is functioning correctly. Refer to the unit's schematic diagram to complete the following steps:

De-energize the input line to the voltage regulator; place the OUTPUT VOLTAGE RANGE switch in the center (off) position, and remove POWER LIGHT-MOTOR fuses F1 and F2 on each control module.

Apply 115 volts AC between terminals A1-TB1-1 and A1-TB1-2 on the control module, or to the corresponding terminals at the motor board terminal strip (TB1). These nine junction terminal strips are connected point-for-point. The motor should turn the variable transformer counter clockwise (viewed from top) so as to lower the output voltage until it reaches the end of its travel, where the limit switch will prevent further rotation in that direction.

Apply 115 volts between terminals A1-TB1-1 and A1-TB1-3 should run the motor in the opposite direction until a limit switch stops the motor at the end of travel.

If the motor operates successfully in this test the problem may be with the control board.

7.9. Inspect the POWERSTAT Variable Transformer brush(s) and commutator(s) for signs of wear or damage. The brush assemblies on the variable transformer section will not need replacement under normal conditions. When excessive brush wear or commutator damage occurs, it is usually the result of an overload. If either condition exists, the POWERSTAT Variable Transformer section or the brush must be replaced or repaired. Check the load to be sure the output current rating of the voltage regulator is not being exceeded.

Do not attempt to clean a commutator with an abrasive such as sandpaper or a file. This will ruin the soft precious metal plating on the commutator surface and will shorten the life of the unit. It is normal for commutators to become black due to carbon brush tracking. If a commutator is to be cleaned, use denatured alcohol and a soft cloth.

7.10. Check the variable transformer radiator(s) (the die cast part that holds the brush assembly) for signs of slippage, and see if all brushes driven by the same motor are aligned with each other. The alignment of the radiator and brushes depends on the setscrews that hold the variable transformer center tube(s) to the shaft and the setscrews that hold the radiator to the center tube. Adjust and tighten as needed.

8.0. RATING

8.1. POWER RATINGS

The WHR5206 ratings are shown below:

INPUT:

VOLTAGE:	240	X	208
FREQUENCY:	50/60 Hz	X	50/60 Hz
MAX CURRENT:	31	X	31
RANGE:	-17% to +17% of Selected Output		
CONNECTION:	Single Phase, 2 Wire		

OUTPUT:

VOLTAGE:	240	X	208
MAX CURRENT:	25		25
MAX kVA	6.0	X	5.2
CONNECTION:	Single Phase, 2 Wire		

GENERAL SPECIFICATIONS

Electrical:

Output Accuracy	Adjustable from $\pm 0.5\%$ to $\pm 3\%$
Response Time	0.025 seconds at 60 Hz, 0.030 seconds at 50 Hz
Load Capacity	100% rated continuous 200% rated 60 seconds 400% rated 3 seconds 600% rated 1 second 800% rated 0.5 second 1000% to 2500% 1/2 cycle inrush
Load Power Factor	0 lagging to 0 leading
Load Crest Factor	6 Max (I peak / I RMS)
Efficiency	99% typical, at full load
Heat Generated	BTU (typical) = 35 x rated kVA
Harmonic Distortion	Less than 1% added
Surge Withstand Capability	6000 volts per IEEE C62.41, location category B
Impedance	1% typical

Environmental:

Service Conditions	Units are housed in 19 inch rack enclosures, intended for indoor use under usual service conditions.									
Temperature	Average ambient temperature for any 24 hour period not to exceed 30°C (86°F), and maximum temperature not to exceed 40°C (104°F). Average ambient temperature for any 24 hour period may be increased to 40°C (104°F), and the maximum temperature may be increased to 50°C (122°F), if the load is decreased to 90% of standard rating. Minimum temperature is 0°C (32°F).									
Storage	-40°C to +70°C (-40°F to +158°F)									
Humidity (Operating and Storage)	10 to 75% average relative humidity for any 7 day period, and maximum relative humidity not to exceed 95% non-condensing.									
Altitude										
Operating	<table border="1"> <thead> <tr> <th>Maximum Altitude</th> <th>Derating</th> </tr> </thead> <tbody> <tr> <td>6,600 Ft. (2,000 meters)</td> <td>No de-rating</td> </tr> <tr> <td>10,000 Ft. (3,000 meters)</td> <td>load to 95%, ambient 30°C (86°F)</td> </tr> <tr> <td>15,000 Ft. (4,500 meters)</td> <td>load to 90%, ambient 20°C (68°F)</td> </tr> </tbody> </table>	Maximum Altitude	Derating	6,600 Ft. (2,000 meters)	No de-rating	10,000 Ft. (3,000 meters)	load to 95%, ambient 30°C (86°F)	15,000 Ft. (4,500 meters)	load to 90%, ambient 20°C (68°F)	
Maximum Altitude	Derating									
6,600 Ft. (2,000 meters)	No de-rating									
10,000 Ft. (3,000 meters)	load to 95%, ambient 30°C (86°F)									
15,000 Ft. (4,500 meters)	load to 90%, ambient 20°C (68°F)									
Storage	50,000 Ft. (15,000 meters) max									

9.0. REPLACEMENT PARTS

9.1. ORDERING

This manual covers the WHR5206 STABILINE® Automatic Voltage Regulator. It is impractical to provide a full list of replacement parts. To order a part not listed in this manual, provide the unit model number, serial number, and date code. Reference the part by schematic reference symbol, description and part number if available.

9.2. CONTROL MODULE ASSEMBLY

The control module used in the WHR5206 STABILINE® Automatic Voltage Regulator is shown below. Other WHR Series regulators have similar control modules but some of the parts are different with **different part number**. Do not use this is manual for any unit other than the one it was intended for.

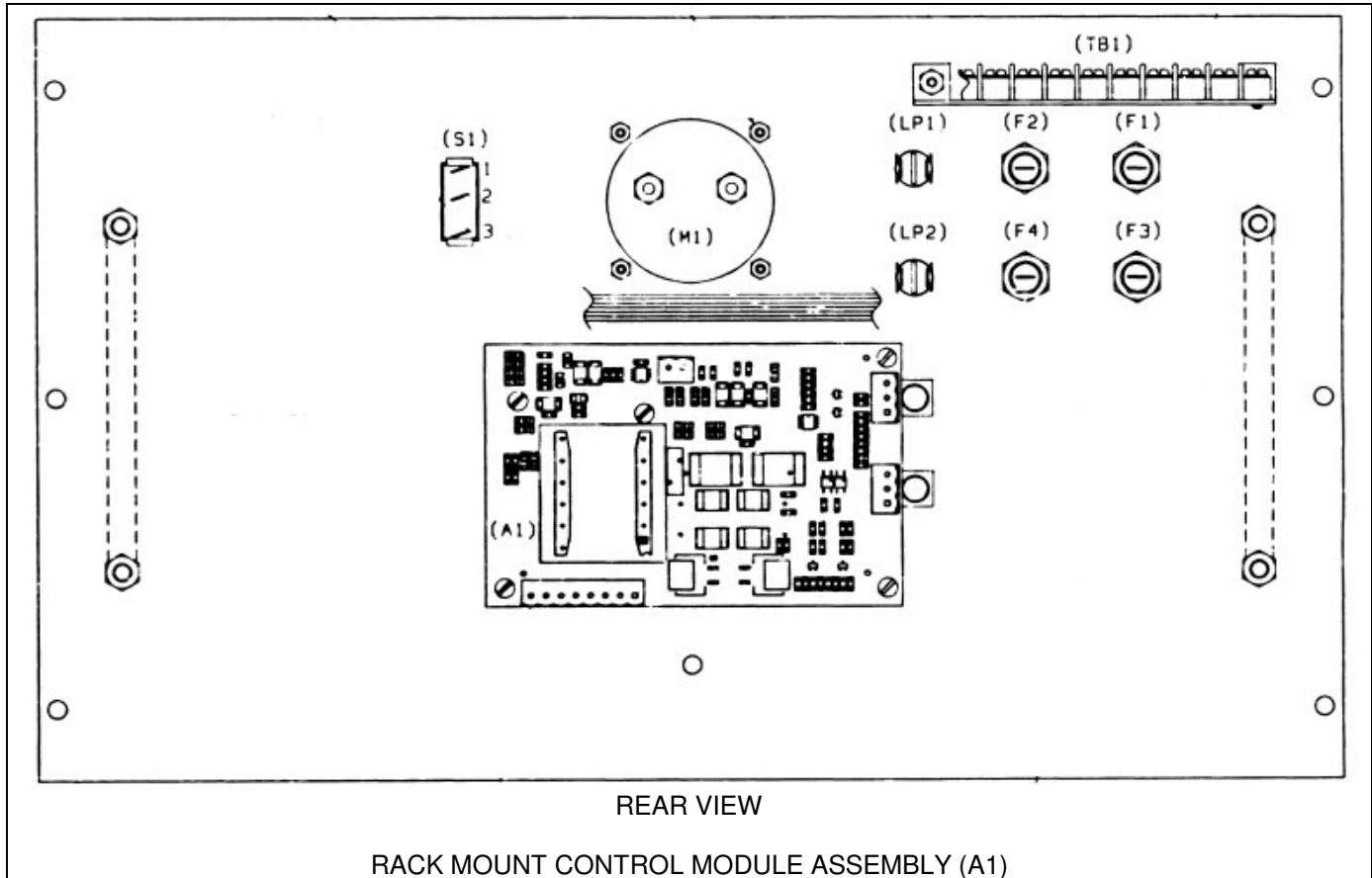

Reference Symbol	Part Description	Standard Part Number
A1	CONTROL MODULE	219452-004
A1-A1	CONTROL BOARD	227412-005
A1-F1,F2,F3,F4	FUSE, 1A, 250V	104364-003
A1-LP1,LP2	LIGHT, INDICATOR, GREEN	227571-001
A1-M1	VOLTMETER	212917-002
A1-S1	SWITCH, ROCKER SPDT ON/OFF/ON	227572-001

9.3. POWER COMPONENTS

The parts listed below are for the WHR5206 STABILINE[®] Automatic Voltage Regulator power section.

Reference Symbol	Part Description	Part Number
B1	MOTOR, AC	228870-002
R1 & C1	RC NETWORK	228978-001
S1,S2	SWITCH	058743-001
T1	POWERSTAT, VARIABLE TRANSFORMER	229095-001
	REPLACEMENT BRUSH ASSEMBLY FOR T1	056135-002
T1 including B1, C1, R1, S1, S2	ASSEMBLY, VARIABLE TRANSFORMER AND MOTOR DRIVE	229091-001
T2	TRANSFORMER, BUCK-BOOST	229086-001

9.4. REPLACEMENT BRUSH ASSEMBLY

Each POWERSTAT[®] Variable Transformer contains a durable brush assembly. These assemblies are designed to reduce the need for attention or replacement; however, because these are moving parts that rely on contact friction to operate properly, an annual inspection is suggested. Refer to the maintenance section of this manual for details. The replacement brush assembly is listed along with its corresponding POWERSTAT Variable Transformer in the power component section.

10.0. SCHEMATIC (For reference only, use full size supplied with unit)

RATINGS:
INPUT: 240 V (±17%) ; 50/60 Hz, SINGLE PHASE, 2 WIRE PLUS SAFETY GROUND.
OUTPUT: 240 V, 25 A MAX, 6.0 KVA MAX.

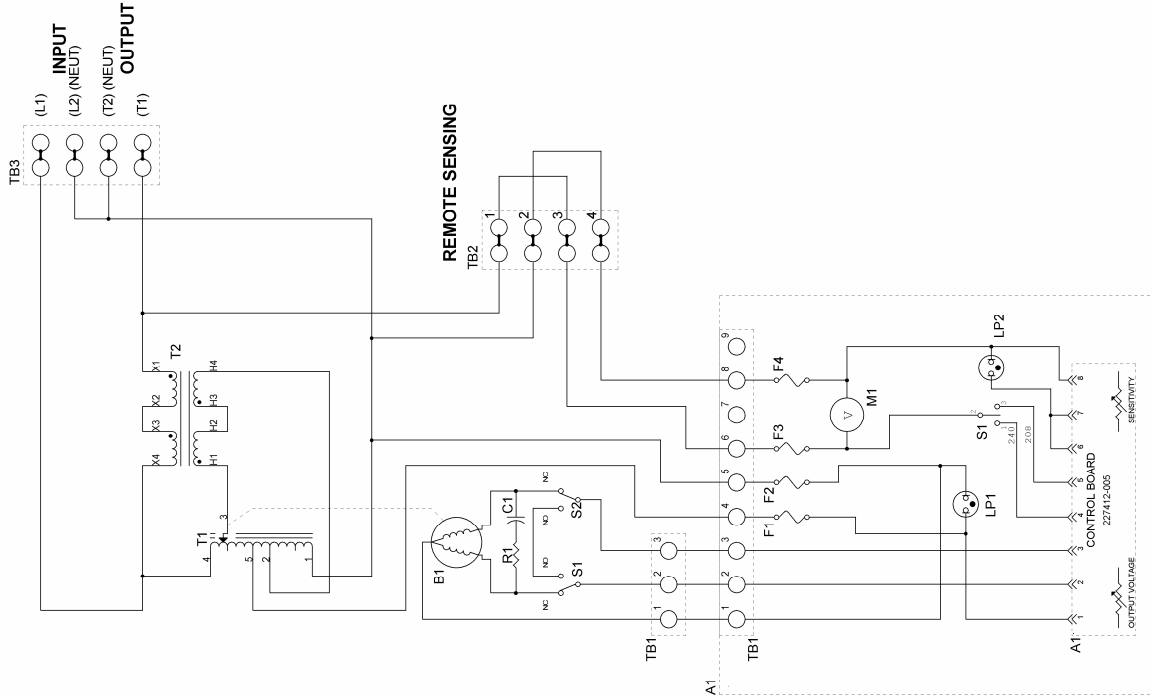

REFERENCE SYMBOL	PART DESCRIPTION
A1	CONTROL MODULE
-A1	CONTROL BOARD
-F1-F4	FUSE, 250V
-L1, L2	LIGHT INDICATOR, GRN
-S1	METER
-S2	ROCKER SWITCH ON/OFF
-TB1	TERMINAL STRIP, CONTROL, 9 TERM.
B1	MOTOR, AC
C1	CAPACITOR
R1	RESISTOR
S1, S2	SWITCH, LIMIT
T1	POWERSTAT, VARIABLE TRANSFORMER
T2	TRANSFORMER, BUCK-BOOST
TB1	TERMINAL STRIP, MOTOR BD, 3 TERM.
TB2	TERMINAL STRIP, REMOTE SENSE, 4 TERM.
TB3	TERMINAL STRIP, I/O, 4 TERM.

NOTES:
 1) REMOTE SENSING CONNECTIONS ARE PROVIDED ON TERMINALS #3 AND #4 OF TB2. TO CONNECT REMOTE SENSING, REMOVE THE TWO JUMPERS BETWEEN TERMINALS #1 AND #3 AND TERMINALS #2 AND #4. CONNECT REMOTE SENSING LEADS TO TERMINALS #3 AND #4.

A	EC 96068	ISSUE FOR RELEASE	TCC	10/10/05	JW
DWG/REV/	EC/NUMBER	REVISION/DESCRIPTION	DATE	DATE	APPD
TITLE SCHEMATIC, WHR5206					
Superior Electric 383 Middle Street Bristol, CT 06010					
SIZE C 229088-001					
DATE 01/15/03 SCALE NONE					
DATE 10/10/05 FSCM NO. 96474 SHEET 1 OF 1					

Available Coast-To-Coast and Internationally

Voltage Control Components

POWERSTAT [®]	Variable Transformers
VOLT-PAC [®]	Variable Transformers
LUXTROL [®]	Lighting Controls
5-WAY [®]	Binding Posts
SUPERCON [®]	Electrical Connectors

Voltage Control Components are available worldwide through an extensive Authorized Stocking Distributor network. These Distributors offer literature, technical assistance and a wide range of models off-the-shelf for fastest possible delivery and service.

Power Quality Solutions

STABILINE [®]	Automatic Voltage Regulators
STABILINE [®]	Transient Voltage Surge Suppressors
STABILINE [®]	Uninterruptible Power Supplies
STABILINE [®]	Power Conditioners

STABILINE Power Quality Solutions are available worldwide through an extensive Authorized Distributor and Reseller network, which offer literature, technical assistance and a select range of models off-the-shelf for fastest possible delivery and service.

In addition, Superior Electric Manufacturer's Representatives are available to provide prompt attention to customer needs. Call or fax for ordering and application information or for the address of the closest Manufacturer's Representative, Authorized Distributor or Reseller.



Superior Electric



Telephone and Fax Numbers

Telephone 860-507-2025
Fax: 860-507-2050

Customer Service: 860-507-2025 Ext. 70782
Product Application 860-507-2025 Ext. 72058

Toll-Free (in U.S.A. and Canada only)

Telephone 1-800-787-3532
Fax: 1-800-821-1369

Customer Service: 1-800-787-3532 Ext. 70782
Product Application: 1-800-787-3532 Ext. 70058

28 Spring Lane • Suite 3 • Farmington, CT 06032
www.superiorelectric.com

The right to make engineering refinements on all products is reserved. Dimensions and other details are subject to change.

213709-203B manual WHR5206.doc